

0101-8021-0

*Temescal*

Model SFIH-270-3  
Single Hearth  
Electron Beam Source

**Ferrotec**



**December 1989**

Temescal, a division of Ferrotec (USA) Corporation  
4569-C Las Positas Road, Livermore, CA 94551  
Tel: 1-800-522-1215; Fax: 925-449-4096



# Contents

---

| <u>Section Number and Title</u>             | <u>Page Number</u> |
|---|--------------------|
| I Basic Principles .....                    | 2                  |
| II Description .....                        | 3                  |
| III Specifications .....                    | 4                  |
| IV Installation.....                        | 5                  |
| V Operating Procedures .....                | 8                  |
| VI Filament Replacement and Adjustment..... | 12                 |
| VII Maintenance.....                        | 22                 |
| VIII Troubleshooting .....                  | 24                 |
| IX Parts List .....                         | 26                 |

The Model SFIH-270-3 electron beam source is covered by one or more of the following United States patents: 3,177,535; 3,483,417. Other patents pending.

# *List of Illustrations*

---

| <u>Figure Number and Title</u>                      | <u>Page Number</u> |
|---|--------------------|
| Figure 1 3-1/4" SFIH-270° Electron Beam Source..... | 1                  |
| Figure 2 Normal Pool Height.....                    | 8                  |
| Figure 3 Focus Sweep Direction.....                 | 9                  |
| Figure 4 Filament Alignment.....                    | 21                 |

# *Attached Drawings*

---

- 303-9324-E 3-1/4" SFIH-270° Electron Beam Source Assembly
- 303-9334-2 Emitter Assembly

## **SAFETY INSTRUCTIONS FOR OPERATING AND SERVICE PERSONNEL**

Operators and service personnel should always wear safety glasses. Operators shall not enter areas intended for service access only. Only experienced service personnel should enter such areas, and only after taking the preliminary precautions described in paragraphs 1 through 6 below.

### **DANGER**

**Potentially lethal voltages may exist within this unit, even with the line power switched off. Service should only be attempted by qualified personnel. Failure to observe all safety precautions may result in personal injury.**

This component is designed to operate as part of a system containing high-voltage equipment. Observe the precautions described below when servicing this system, especially when servicing components where high voltages may be present.

1. Before servicing or operating this equipment, read all the component manuals supplied with the system, paying special attention to safety instructions.
2. Post HIGH VOLTAGE WARNING signs in conspicuous locations within the service area.
3. Remove rings, watches, bracelets, and any other metal jewelry before working around high voltage.
4. DO NOT WORK ALONE!
5. Be sure that all equipment is connected to a power receptacle having the correct polarity and grounding, as prescribed by the local electrical codes. Refer to the power supply portion of the documentation to determine the proper electrical ground for high-voltage components.
6. Before servicing any high-voltage component, switch off the electrical power at the component's main power switch. This switch should have a lockout feature. Lock the power off and keep the key with you while you are working on the equipment.
7. Certain electrical parts (e.g., electrolytic capacitors) hold a lethal voltage even after the power is switched off. Before entering any service area, use a grounding hook to discharge such parts. Be sure that these parts are discharged before starting any repairs.
8. DO NOT touch high-voltage leads unless power is off and a grounding hook is connected to the parts to be serviced.
9. The high-voltage components of the system should be equipped with electrical interlocks to protect personnel from injury. DO NOT ATTEMPT TO DEFEAT, OVERRIDE, OR BYPASS THESE PROTECTIVE DEVICES!
10. Never leave loose ends on high-voltage connections.
11. Observe the following warning if the system employs Radio Frequency (RF) power.

### **DANGER**

**RF radiation—even at modest power levels—can cause serious injury. If any of the RF components (e.g., the RF power supply, the RF matching network, or the RF electrodes or shielding inside the product chamber) are moved or changed in any way, the RF energy may be radiated outside the equipment. Monitor the equipment to assure that external RF radiation is below the levels prescribed by any and all applicable safety codes.**

## **Special Amendment for United Kingdom Users**

### **All Electrical Power Sources: Safety Precautions**

This component is designed to be used in an extra-high-voltage system. Only authorized personnel should be permitted to carry out work on this system.

Prior to any servicing, grounding hooks should be used to short out all high-voltage parts and conductors in both the vacuum system and the high-voltage power supply. Screens protecting extra-high-voltage conductors should be removed only if appropriate action has been taken to ensure that extra-high-voltage conductors are dead and cannot be reenergized inadvertently.

In addition, all personnel should be aware of:

1. The Electricity (Factories Act) Special Regulations (1908 and 1944), in particular, Regulations 18(d) and 28 of the 1980 Regulations, as amended; and
2. The employer's responsibility to set up suitable systems to safeguard the health and safety of employees, according to the Health & Safety at Work etc. Act (1974).

## **USER RESPONSIBILITY**

This equipment will perform in accordance with the instructions and information contained in the user's manual and its referenced documents when such equipment is installed, operated, and maintained in compliance with such instructions. The equipment must be checked periodically. Defective equipment shall not be used. Parts that are broken, missing, plainly worn, distorted, or contaminated, shall be replaced immediately. Should such repair or replacement become necessary, a telephone or written request for service should be made to Temescal, Livermore, CA, a division of Ferrotec (USA) Corp.

The equipment, or any of its parts, shall not be altered without the prior written approval of Temescal. The user and/or purchaser of this equipment shall have the sole responsibility for any malfunction which results from improper use, faulty maintenance, damage, improper repair, or alteration by any party other than Temescal.

## **GUIDELINES AND GOOD PRACTICES**

1. Follow applicable clean room procedures (smocks, masks, gloves, etc.).
2. Do not expose the vent and purge valves to excessive pressures. The nitrogen line regulator is factory set at 15 psi and must not be adjusted above 20 psi.
3. Prevent oil, grease, water, sweat, etc. from getting into the vacuum chamber.
4. Replace the source tray shield correctly to ensure that the ceramic parts of the high voltage feedthroughs are protected from being coated.
5. Clean all mechanical parts and seals with lint-free paper/cloth soaked with isopropyl alcohol (IPA). Dispose of all IPA-exposed cleaning paper/cloth in a fireproof container, while ensuring proper safety precautions are being followed.
6. Polish scratched surfaces with Scotch-Brite, taking care not to produce any cross scratches.
7. Shaft seals are all ferromagnetic. No lubrication is required.
8. Check the chamber door's seal and sealing surfaces each time before closing it.
9. Check and clean the source tray seals and sealing surfaces with IPA each time before raising the source tray into place.
10. Staff must be trained by competent personnel. DO NOT allow staff to operate the system or do maintenance and recovery work on it until they are trained by competent personnel.
11. Document all alarms, deviations, breakdowns, and servicings, either on hardcopy or on an electronic equipment-log system.

## HEALTH HAZARD

The condensates deposited on the tank walls of a vacuum system are generally in the form of extremely fine particles. The nature, as well as the form, of the materials poses the following potential health hazards:

- a) Inhaling fine particles (powder) may cause damage to the lungs. To help prevent this, wear a protective respirator mask with fine filter that has been approved by the National Institute for Occupational Safety and Health (NIOSH) and the federal Mine Safety and Health Administration (MSHA).
- b) Some substances are toxic and inhaling them should be avoided. Take steps to ascertain whether or not the material being deposited is a known toxic substance. Refer to the Material Safety Data Sheet(s) covering the evaporant(s) in question.
- c) Certain powders (titanium, for instance) can cause flash fires when exposed to oxygen or other oxidizers. Therefore, when opening the chamber door after a deposition cycle, exercise extreme caution and allow time for the coating surface to oxidize. Breakage of some of the more reactive condensates may be hazardous, even when the above precautions are observed. In this situation, fire-protective clothing should be worn.
- d) Certain powders (platinum, for instance) are known to catalyze methyl alcohol vapors upon contact, generating heat in the process and possibly causing a fire to erupt. Therefore, never use methyl alcohol to wipe down or clean any internal tank surfaces of a vacuum system. Use isopropyl alcohol (IPA), instead. Dispose of all IPA-exposed lint-free paper/cloth into a fireproof container, while ensuring all proper safety procedures and precautions are being followed.



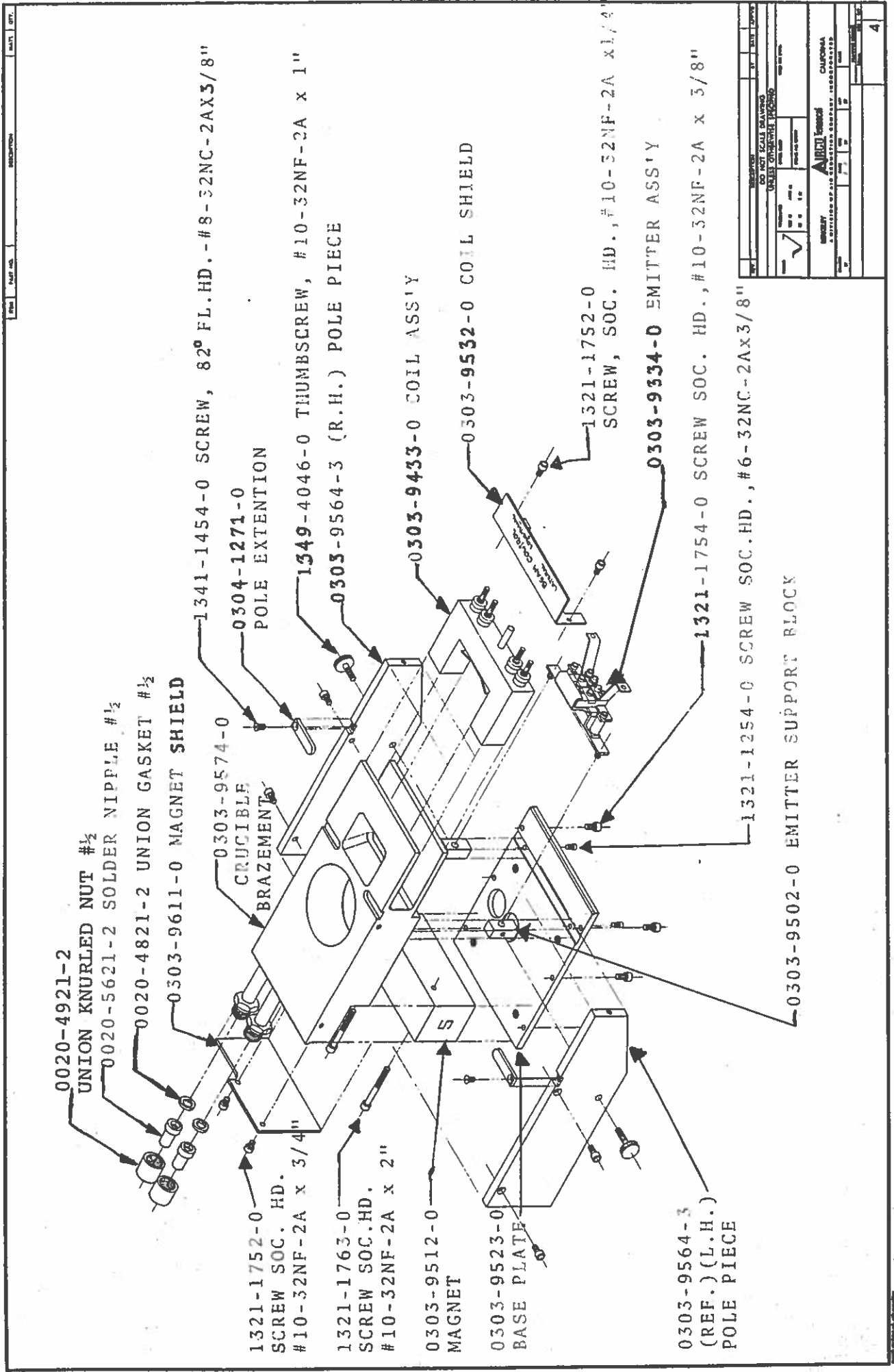

Figure 1

## I. BASIC PRINCIPLES

The Airco Temescal Electron-Beam-Source operates on principles similar to a cathode-ray tube, where the cathode (tungsten filament) is operated at a negative high-voltage potential; and the electrons are accelerated in the form of a beam into the crucible, which is at ground potential. The filament is secured in a five-sided cavity (with opening at front), bounded by cathode blocks and a beam former, all at cathode potential. The filament is heated to incandescence, causing electrons to be emitted in random directions. Space charges are formed by the emitted electrons at the five sides of the cavity, forcing electrons emitted in these directions to return to the filament. Only electrons emitted at the front of the cavity escape. These electrons are accelerated by an anode potential. During this acceleration, they are electrostatically focused into a beam form, the anode operating similar to a single aperture lens. After the electron beam passes the anode, it is both deflected and further focused by a transverse magnetic field through a beam passage opening in the hearth onto the evaporant material in the crucible.

In essence, an electron beam is a stream of energetic charged particles flowing from a cathode emitter and accelerated typically by a high voltage D.C. power supply. The kinetic energy of this stream of charged particles becomes random energy (heat) when the electrons strike a surface. This energy, which is dissipated into the surface, can melt and evaporate any known material.

## II. DESCRIPTION

The Airco Temescal Electron-Beam-Source, Model SFIH-270°-3, is a high power, high rate, large crucible capacity, heavy-duty source designed for long duration production applications.

The SFIH-270°-3 Electron Beam Source features:

1. A large, water-cooled, copper conical crucible (3-1/4" dia. top, 2-7/16" dia. bottom, 1-1/2" deep), for longer uninterrupted runs.
2. A hidden, easily removable, plug-in type, emitter assembly with 270° beam deflection, giving a filament life of 10 to 20 times longer than 180° sources.
3. A hermetically sealed deflection electromagnet which provides full X and Y beam sweep with high frequency capability for the ultimate in evaporation versatility.
4. A main field permanent magnet which insures that the beam is always impinging on the hearth area, preventing beam damage if the electromagnet fails.
5. Beam Spot size adjustment capability for optimum beam density.
6. This Source is bakeable to 250°C.
7. This Source is adaptable to wire feed or rod feed applications.

The SFIH-270°-3 Electron Beam Source represents significant technical achievements which, with high rates and large capacity, establishes this Source as an ideal production tool.

### III. SPECIFICATIONS

|                                |  |
|--------------------------------|--|
| Description                    | Electron Beam Source, Model SFIH-270°-3.   |
| Evaporation Rate               | Up to 40,000 Angstroms per minute on aluminum at 14 KW at 10" high.                          |
| Source Power                   | 20 KW max (10,000 volts at 2 amps).  |
| Filament Power                 | 75 amps max., 6 VAC max.   |
| Efficiency                     | >99% beam power into the crucible.   |
| Deflection Electromagnet Power |  |
| Longitudinal Sweep             | 0-2 amps, 10 VDC max.  |
| Lateral Sweep                  | 0-2 amps, 10 VDC max.  |
| Longitudinal Resistance        | 1.4 ohms   |
| Lateral Resistance             | 1.0 ohms   |
| Permanent Magnet               | 450 Gauss at magnet center.  |
| Crucible Size                  | Conical with flat bottom: 3-1/4" dia. top, 2-7/16" dia. bottom, 1-1/2" deep 157 cc capacity. |
| Cooling Water                  |  |
| Temperature                    | 60°F or less   |
| Flow                           | Minimum of 4 gal. per minute.  |
| Pressure                       | Maximum 100 PSIG.  |
| Pressure Differential          | 40 PSIG minimum required for desired flow rate.  |
| Lines                          | 1/2" O.D.  |
| Source Size and Weight         | 3-3/8" H x 6" W x 12" D (excluding water lines), 30 pounds.                                  |

#### IV. INSTALLATION HOOK-UP

To mount the Source in a chamber, the following accessories are necessary and available from Airco Temescal:

| <u>Qty.</u> | <u>Description</u>       | <u>ATD Part Number</u>                                |
|-------------|--------------------------|---|
| 2           | High-Voltage Feedthrough | 0302-2573-0 (Metal Seal)<br>0718-8483-0 (O-ring Seal) |
| 1           | Focus Coil Feedthrough   | 0402-7463-0 (Metal Seal)<br>0502-0093-0 (O-ring Seal) |
| 1           | Water Feedthrough        | 0302-6022-0 (Metal Seal)<br>0718-9193-0 (O-ring Seal) |
| 1           | Water Flow Switch        | 9102-0001-0   |

#### Mechanical Hook-up:

1. Bolt the Source securely to the chamber baseplate, to insure good ground contact.
2. Using 1/2" O.D. tubing, connect the Source water lines to the water feedthrough. On the outside water lines, connect the water flow switch to the water "out" line of the source.
3. The shape of the electron-beam path requires that the shutter be no less than 4 inches above the Source. A greater distance is desirable and will result in less heating and slower build-up on the shutter.

#### Electrical Hook-up in Vacuum:

Electrical conductor sizes below are based on a current density of 1000 amperes per sq. in. in vacuum. To minimize coating build-up which can cause unnecessary arcing, keep all leads as short and as low as possible.

#### IV. INSTALLATION HOOK-UP (cont)

##### Electrical Hook-up in Vacuum (continued)

##### 1. High-Voltage Leads (two required):

Use #6 AWG flexible bare-wire leads as supplied with Source, or as an alternate, use 1/16" x 1/2" copper strap. The leads are to be spaced a minimum of 3/8" from any ground potential and each other.

##### 2. Coil Leads (two required for longitudinal positioning; two additional leads required with lateral sweep controls):

Longitudinal leads, use #16 AWG wire. Lateral leads, if sweep control is used, use #16 AWG wire.

NOTE: Polarity (+ and -) of longitudinal coil leads is marked on the coil shield. Make sure that proper connection is made to the power supply. A reversed polarity will cause the beam to reverse and possibly damage the system.

##### Electrical Hook-up in Atmosphere:

##### 1. High-voltage Leads:

Use 1/4" dia. copper rod as supplied with Airco Temescal power supply. The leads are to be spaced a minimum of 1-1/2" from any ground potential and each other (for 10,000 volts).

##### 2. Coil Leads (longitudinal and lateral):

Use #16 AWG wire.

##### 3. Water Flow Switch Lead:

Use #16 AWG wire.

#### IV INSTALLATION HOOK-UP (cont)

##### Electrical Hook-up in Atmosphere (continued)

The system and power supply must be joined to a common earth ground. The Source is grounded through the mounting plate to the chamber and back to the power supply through the low-impedance grounding cable.

NOTE: Refer to grounding instructions in appropriate power supply manual for details of system grounding.

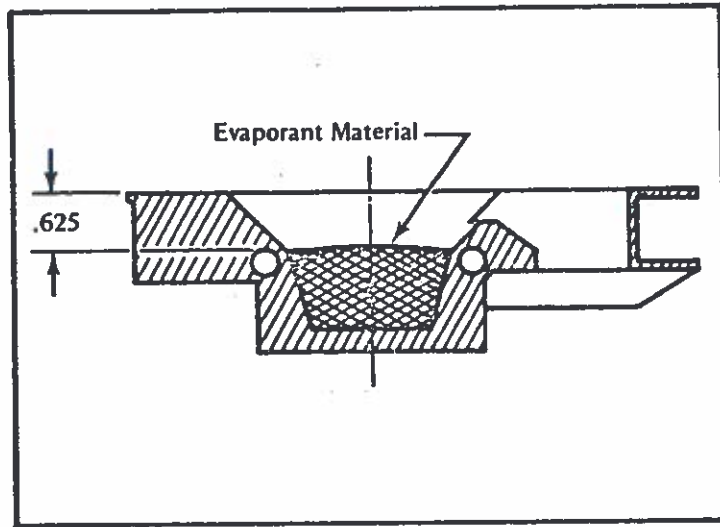

Figure 2  
Normal pool height



## V. OPERATING PROCEDURES

There are four controlled operating variables: 1) emission voltage, 2) emission current, 3) filament current, and 4) focus current.

The cooling water to the crucible is to be constant, a minimum of 4 gal. per minute, and must be flowing at all times when the Source is operated to prevent crucible damage.

NOTE: A flow switch for the Source is required to satisfy the gun water interlock on the associated Airco Temescal power supply.

The emission voltage may be fixed or variable, depending on the power supply. The focus current (longitudinal) moves the beam spot closer or farther away from the coil.

### Source Start-up

1. With the vacuum chamber at atmospheric pressure, place the evaporant material in the crucible.

NOTE: If there is not sufficient evaporant material, the beam may damage the crucible. Therefore, the crucible should be at least half full.

2. Check gun water interlock to be certain that the cooling water is flowing through the crucible.
3. Evacuate the vacuum chamber to  $1 \times 10^{-4}$  torr, (0.1 micron or less).
4. Emission Voltage Setting (if applicable):
  - a) Turn on the emission voltage.
  - b) Set the emission voltage control to operating voltage.

V. OPERATING PROCEDURES (cont)

5. Focus Current Setting:

- a) Set the focus current control to its lowest setting.
- b) Turn on the focus current.
- c) Adjust the focus current (longitudinal) to 0.75 amps nominal at 10,000 volts operation. Experience will indicate the amount of current variation required to direct the beam to the crucible center. Lower current is required for lower operating voltage.

NOTE: 0 amps should be required for lateral centering.

When the focus current is increased, the beam will move from the farthest edge of the crucible toward the coil. Focus sweep direction as shown.

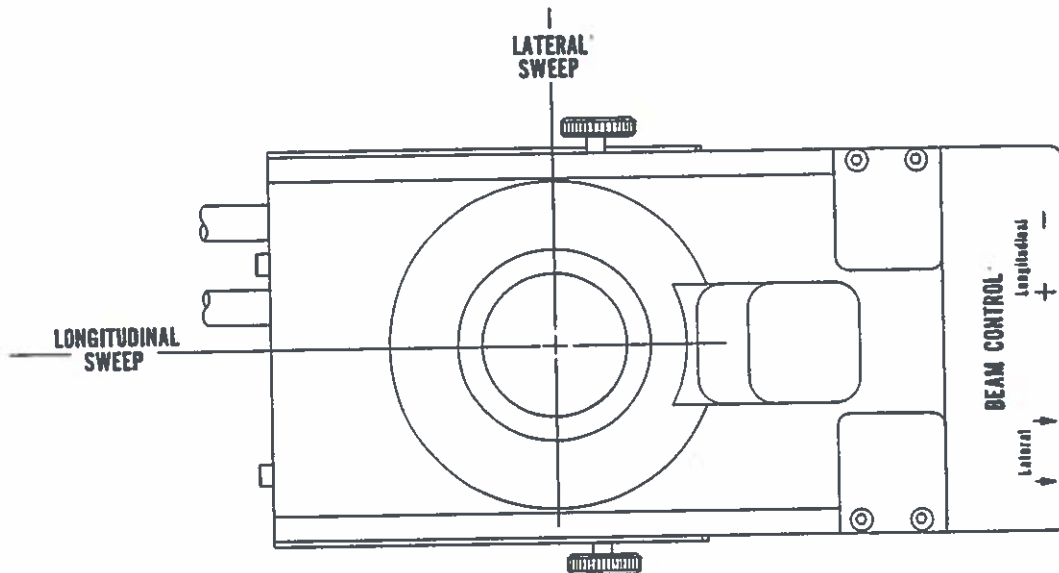

Figure 3

V. OPERATING PROCEDURES (cont)

6. Emission Current Setting:

- a) Set the emission current control to its lowest setting.
- b) Turn on the Source filament.

7. Bring emission current up to 20 milliamps. A fluorescent area should now be seen on or near the evaporant material.

CAUTION: If no fluorescent area appears, coil polarity may have been reversed, causing the beam to be turned down from the filament instead of up. Check to see if the fluorescent area is visible below the emitter assembly. Reverse the coil connections if necessary.

Adjust the focus current control (reference Item 5 of Section V above) so the fluorescent area is centered on the evaporant material, not on the crucible. A beam spot on the crucible will evaporate the copper from the crucible. Increase the emission current slowly until a beam spot appears in the fluorescent area. Adjust the focus current as necessary.

8. Slowly increase the emission current to the desired power level using proper evaporation techniques.

9. Beam Spot Size Adjustment:

The spot size can be enlarged by removing the pole extensions (see Figure #1). Generally at higher power levels (8-20 KW) a higher rate of evaporation can be achieved with the larger beam spot size.

This Source is now ready to operate. If trouble is experienced at any point, refer to the Trouble-Shooting Chart.



PARTS LIST

PARENT PART: 0303-9334-0

EMITTER ASSY SFIH-3  
 ERC: 2, SRCE CODE: A TYPE: 1 UM: EA PC: 33-SALE ASSEMBLY QTY: 1  
 DATE: 05-Jun-85

| ITEM NO | COMPONENT PART NUMBER | ERC        | DESCRIPTION                     | S T S A P    | EXTENDED | START | CLOSE | OPR | LT  | STORES  |
|---------|-----------------------|------------|---------------------------------|--------------|----------|-------|-------|-----|-----|---------|
|         |                       | PROD. CODE | COM. CD                         | C Y P B L UM | QTY PER  | DATE  | DATE  | SEQ | OFF | ACCOUNT |
| 0001    | 0303-9351-0           | C          | FILAMENT SFIH-270 .080X7.5TURN  | P 1 P B P EA | 1        |       |       | 10  | 0   | STR     |
| 0002    | 0303-3131-0           | Z          | H.V. INSULATOR, FLANGED         | P 1 P B F EA | 4        |       |       | 10  | 0   | STR     |
| 0003    | 0303-3152-0           | C          | EMITTER SUPPORT BRACKET         | P 1 P C F EA | 1        |       |       | 10  | 0   | STR     |
| 0004    | 0303-3161-0           | D          | SUPPORT STUD                    | P 1 P C F EA | 2        |       |       | 10  | 0   | STR     |
| 0005    | 0303-9362-0           | D          | CATHODE BLOCK L.H.              | P 1 P B F EA | 1        |       |       | 10  | 0   | STR     |
| 0006    | 0303-9372-0           | B          | CATHODE BLOCK R.H.              | P 1 P B F EA | 1        |       |       | 10  | 0   | STR     |
| 0007    | 0303-9382-0           | C          | FILAMENT CLAMP                  | P 1 P B F EA | 2        |       |       | 10  | 0   | STR     |
| 0008    | 0303-6721-0           | O          | LOCATING INSULATOR              | P 1 P B F EA | 1        |       |       | 10  | 0   | STR     |
| 0009    | 0415-1822-0           | A          | SFIH 270-2 EBS BEAM FORMER      | P 1 P C F EA | 1        |       |       | 10  | 0   | STR     |
| 0010    | 0303-9402-0           | Z          | ANODE                           | P 1 P B F EA | 1        |       |       | 10  | 0   | STR     |
| 0011    | 0303-9412-0           | A          | MOUNTING BAR                    | P 1 P C F EA | 1        |       |       | 10  | 0   | STR     |
| 0013    | 0418-4631-0           | Z          | SPACING INSULATOR               | P 1 P A P EA | 2        |       |       | 10  | 0   | STR     |
| 0014    | 0303-9422-0           | A          | EMITTER SUPPORT BAR             | P 1 P C P EA | 1        |       |       | 10  | 0   | STR     |
| 0015    | 1321-1251-0           | 3B         | SCREW, SOCHD6-32NC-2AX.1918-855 | X 1 P C P EA | 3        |       |       | 10  | 0   | STR     |
| 0016    | 1321-1252-0           | 3B         | SCREW C SOC 5 6-32 X .250 SST   | X 1 P C P EA | 4        |       |       | 10  | 0   | STR     |
| 0017    | 1474-1200-0           | 3B         | WASHER INTERNAL #6 T-410 SST    | X 1 P C P EA | 2        |       |       | 10  | 0   | STR     |
| 0018    | 1321-1254-0           | 3B         | SCREW C SOC 5 6-32 X .375 SST   | X 1 P C P EA | 4        |       |       | 10  | 0   | STR     |
| 0019    | 1321-1255-0           | 3B         | SCREW C SOC 5 6-32 X .500 SST   | X 1 P C P EA | 2        |       |       | 10  | 0   | STR     |
| 0020    | 1378-1200-0           | 3B         | WASHER FLAT #6 18-B SST         | X 1 P C P EA | 2        |       |       | 10  | 0   | STR     |
| 0021    | 1360-1200-0           | 3B         | NUT MACHINE 6-32                | X 1 P C P EA | 2        |       |       | 10  | 0   | STR     |
| 1201    | 0303-3122-1           | E          | FILAMENT BUSS BAR LH            | P 1 P B P EA | 1        |       |       | 10  | 0   | STR     |
| 1202    | 0303-3122-2           | E          | FILAMENT BUSS BAR RH            | P 1 P B P EA | 1        |       |       | 10  | 0   | STR     |

NOTES:





PARTS LIST

PARENT PART: 0303-9324-0

SFIH-270-3 E.B. SOURCE ASSY  
ERC: E SRCE CODE: A TYPE: 1 UM: EA PC: 33-SALE  
DATE: 14-Aug-86

ASSEMBLY QTY: 1

| ITEM NO | COMPONENT PART NUMBER | ERC        | DESCRIPTION     | S T S A P              | EXTENDED QTY PER | START DATE | S/N | CLOSE DATE | S/N | OPR LT  | STORES  |
|---------|-----------------------|------------|-----------------|------------------------|------------------|------------|-----|------------|-----|---------|---------|
| NO      |                       | PROD. CODE | COM. CD         | C Y P B L UM           |                  | DATE       |     | DATE       |     | SEQ OFF | ACCOUNT |
| 0001    | 0020-4821-2           | 0          | 1/2 RL GASKET   | VITON                  |                  |            |     |            |     |         |         |
| 0002    | 0020-4921-2           | D          | 1/2 RL NUT      | SST                    | P 1 P C P EA     |            |     |            |     | 40      | 0 STR   |
| 0003    | 0020-5621-2           | D          | 1/2 RL SOLDER   | NIP SST                | P 1 P B P EA     |            |     |            |     | 40      | 0 STR   |
| 0005    | 0216-1951-0           | A          | SHUNT BAR       |                        | P 1 P B P EA     |            |     |            |     | 40      | 0 STR   |
| 0006    | 0303-3292-0           | G          | FILAMENT LEAD   |                        | P 1 P C P EA     |            |     |            |     | 40      | 0 STR   |
| 0008    | 0303-9433-0           | 33-SALE    | COIL ASSY       | 3-1/4" SFIH            | A 1 P C F EA     |            |     |            |     | 40      | 0 STR   |
| 0009    | 0303-9502-0           | C          | EMITTER SUPPORT | BLOCK                  | A 1 P A F EA     |            |     |            |     | 40      | 0 STR   |
| 0010    | 0303-9512-0           | C          | MAGNET          | 3-1/4" SFIH            | P 1 P B P EA     |            |     |            |     | 40      | 0 STR   |
| 0011    | 0303-9523-0           | A          | BASE PLATE      | 3-1/4" SFIH            | P 1 P B P EA     |            |     |            |     | 40      | 0 STR   |
| 0012    | 0303-9532-0           | 33         | COIL SHIELD     | 3-1/4" SFIH            | P 1 P B P EA     |            |     |            |     | 40      | 0 STR   |
| 0013    | 0303-9564-1           | D          | POLE PIECE      | LH3-1/4SFI             | F 1 P C P EA     |            |     |            |     | 40      | 0 STR   |
| 0014    | 0303-9564-2           | D          | POLE PIECE      | RH 3-1/4SFI            | P 1 P B P EA     |            |     |            |     | 40      | 0 STR   |
| 0016    | 0303-9611-0           | C          | MAGNET          | SHLD 3 1/4" SFIH       | P 1 P B P EA     |            |     |            |     | 40      | 0 STR   |
| 0017    | 0303-9661-0           | 1          | SPARES KIT      | SFIH-3                 | P 1 P C P EA     |            |     |            |     | 40      | 0 STR   |
| 0018    | 0304-1271-0           | A          | POLE EXT        | 3-1/4" SFIH            | A 1 P B F EA     |            |     |            |     | 60      | 0 STR   |
| 0019    | 1321-1254-0           | 33         | SCREW C         | SOC 5 6-32 X .375 SST  | P 1 P C P EA     |            |     |            |     | 40      | 0 STR   |
|         |                       | 38         | I-19 2EA        | X 1 P C P EA           |                  |            |     |            |     | 40      | 0 STR   |
|         |                       |            | I-718 4EA       |                        |                  |            |     |            |     |         |         |
| 0020    | 1321-1752-0           | 38         | SCREW C         | SOC 5 10-32 X .250 SST | P 1 P C P EA     |            |     |            |     | 40      | 0 STR   |
| 0021    | 1321-1754-0           | 38         | SCREW C         | SOC 5 10-32 X .375 SST | P 1 P C P EA     |            |     |            |     | 40      | 0 STR   |
| 0022    | 1321-1755-0           | 38         | SCREW C         | SOC 5 10-32 X .500 SST | P 1 P C P EA     |            |     |            |     | 40      | 0 STR   |
| 0023    | 1341-1454-0           | 38         | SCREW M         | FLAT 2 8-32 X .375 SST | X 1 P C P EA     |            |     |            |     | 40      | 0 STR   |
| 0024    | 1349-4046-0           | 38         | THUMB SCREW     | 10-32 X 1 SST          | P 1 P C P EA     |            |     |            |     | 40      | 0 STR   |
| 0025    | 1360-1700-0           | 38         | NUT             | HEX 10-32              | P 1 P C P EA     |            |     |            |     | 40      | 0 STR   |
|         |                       |            |                 |                        | X 1 P C P EA     |            |     |            |     | 40      | 0 STR   |



PARTS LIST

PARENT PART: 0303-9324-0

SFIH-270-3 E. B. SOURCE ASSY UM: EA PC: 33-SALE ASSEMBLY QTY: 1  
ERC: E SRCE CODE: A TYPE: 1 ABC: A PL: F DATE: 14-Aug-86

| ITEM NO | COMPONENT PART NUMBER | DESCRIPTION                     | S T S A P    | EXTENDED QTY PER | START DATE | S/N | CLOSE DATE | S/N | OPR LT | STORES |
|---------|-----------------------|---------------------------------|--------------|------------------|------------|-----|------------|-----|--------|--------|
| 0026    | 6990-0015-0           | BONDHUS BALL DRIVER 7/64WRENCH  | P 1 P C P EA | 1                |            |     |            |     | 40     | 0 STR  |
| 0027    | 6990-0016-0           | 5/32 HEX BONDHUS BL DRV         | P 1 P C P EA | 1                |            |     |            |     | 40     | 0 STR  |
| 0028    | 8121-0608-0           | POLY BAGS 6X9X.003              | P 1 P C P EA | 1                |            |     |            |     | 60     | 0 STR  |
| 0029    | 8121-1224-0           | POLY BAGS 12X24                 | P 1 P C P EA | 1                |            |     |            |     | 60     | 0 STR  |
| 0030    | 8130-1073-0           | CORR BOX 19X9 1/4X 5            | P 1 P C P EA | 1                |            |     |            |     | 60     | 0 STR  |
| 0031    | 8130-1073-1           | LEFT HAND PAD                   | P 1 P C P EA | 1                |            |     |            |     | 60     | 0 STR  |
| 0032    | 8130-1073-2           | RIGHT HAND PAD                  | P 1 P C P EA | 1                |            |     |            |     | 60     | 0 STR  |
| 0701    | 0303-9351-0           | FILAMENT SFIH-270 .080X7.5TURN  | P 1 P B P EA | 1                |            |     |            |     | 30     | 0 STR  |
| 0702    | 0303-3131-0           | H. V. INSULATOR, FLANGED        | P 1 P B F EA | 4                |            |     |            |     | 30     | 0 STR  |
| 0703    | 0303-3152-0           | EMITTER SUPPORT BRACKET         | P 1 P C F EA | 1                |            |     |            |     | 30     | 0 STR  |
| 0704    | 0303-3161-0           | SUPPORT STUD                    | P 1 P C F EA | 2                |            |     |            |     | 30     | 0 STR  |
| 0705    | 0303-9362-0           | CATHODE BLOCK L. H.             | P 1 P B F EA | 1                |            |     |            |     | 30     | 0 STR  |
| 0706    | 0303-9372-0           | CATHODE BLOCK R. H.             | P 1 P B F EA | 1                |            |     |            |     | 30     | 0 STR  |
| 0707    | 0303-9382-0           | FILAMENT CLAMP                  | P 1 P B F EA | 2                |            |     |            |     | 30     | 0 STR  |
| 0708    | 0303-6721-0           | LOCATING INSULATOR              | P 1 P B F EA | 1                |            |     |            |     | 30     | 0 STR  |
| 0709    | 0415-1822-0           | SFIH 270-2 EBS BEAM FORMER      | P 1 P C F EA | 1                |            |     |            |     | 30     | 0 STR  |
| 0710    | 0303-9402-0           | ANODE                           | P 1 P B F EA | 1                |            |     |            |     | 30     | 0 STR  |
| 0711    | 0303-9412-0           | MOUNTING BAR                    | P 1 P C F EA | 1                |            |     |            |     | 30     | 0 STR  |
| 0712    | 0303-3122-1           | FILAMENT BUSS BAR LH            | P 1 P B P EA | 1                |            |     |            |     | 30     | 0 STR  |
| 0713    | 0418-4631-0           | SPACING INSULATOR               | P 1 P A P EA | 2                |            |     |            |     | 30     | 0 STR  |
| 0714    | 0303-9422-0           | EMITTER SUPPORT BAR             | P 1 P C P EA | 1                |            |     |            |     | 30     | 0 STR  |
| 0715    | 1321-1251-0           | SCREW, SOCHD6-32NC-2AX.1918-BSS | X 1 P C P EA | 3                |            |     |            |     | 30     | 0 STR  |
| 0716    | 1321-1252-0           | SCREW C SOC 5 6-32 X .250 SST   | X 1 P C P EA | 4                |            |     |            |     | 30     | 0 STR  |





PARTS LIST

PARENT PART: 0303-9324-0

SFIH-270-3 E. B. SOURCE ASSY UM: EA PC: 33-SALE ASSEMBLY QTY: 1  
ERC: E SRCE CODE: A TYPE: 1 ABC: A PL: F DATE: 14-Aug-86

| ITEM NO | COMPONENT PART NUMBER | DESCRIPTION               | S T S A P     | EXTENDED QTY PER | UM: EA | PC: 33-SALE | ASSEMBLY QTY: 1 | DATE | CLOSE DATE | START DATE | S/N | OPR LT  | STORES  |
|---------|-----------------------|---------------------------|---------------|------------------|--------|-------------|-----------------|------|------------|------------|-----|---------|---------|
|         |                       | COM. CD                   | C Y P B L U M |                  |        |             |                 |      |            |            |     | SEG OFF | ACCOUNT |
| 0717    | 1474-1200-0           | WASHER INTERNAL           | #6 T-410 SST  | 2                |        |             |                 |      |            |            |     | 30      | 0 STR   |
| E       |                       | X 1 P C P EA              |               |                  |        |             |                 |      |            |            |     |         |         |
| 0718    | 0303-3122-2           | FILAMENT BUSS BAR         | RH            | 1                |        |             |                 |      |            |            |     | 30      | 0 STR   |
| 0719    | 1321-1255-0           | SCREW C SOC 5 6-32 X .500 | SST           | 2                |        |             |                 |      |            |            |     | 30      | 0 STR   |
| 0720    | 1378-1200-0           | WASHER FLAT #6            | 18-B SST      | 2                |        |             |                 |      |            |            |     | 30      | 0 STR   |
| 0721    | 1360-1200-0           | NUT MACHINE               | 6-32 SST      | 2                |        |             |                 |      |            |            |     | 30      | 0 STR   |
| D       |                       | X 1 P C P EA              |               |                  |        |             |                 |      |            |            |     |         |         |
| 1501    | 0020-5121-2           | 1/2 RL SOLDER             | CPLG SST      | 2                |        |             |                 |      |            |            |     | 20      | 0 STR   |
| C       |                       | P 1 P B P EA              |               |                  |        |             |                 |      |            |            |     |         |         |
| 1502    | 0303-9584-0           | CRUCIBLE (STD)            |               | 2                |        |             |                 |      |            |            |     | 20      | 0 STR   |
| 1505    | 5615-5050-0           | BAR-ROUND 1/2 DIA         | C10100 CU     | 1                |        |             |                 |      |            |            |     | 20      | 0 STR   |
| 1506    | 5470-0504-9           | TUBE 1/2 OD X.049 W       | ASTM-A269     | 1                |        |             |                 |      |            |            |     | 20      | 0 STR   |
|         |                       | R 1 P C P FT              |               | 0.550000         |        |             |                 |      |            |            |     | 20      | 0 STR   |

NOTES:

- OPR 20: CRUCIBLE BRAZE 0303-9574-0
- OPR 30: EMITTER ASSY 0303-9334-0
- OPR 40: FINAL ASSY 0303-9324-0
- OPR 60: PACKAGING



| DRAWING NO.  | REV. | CHK. DATE      | APPV. DATE | AIRCEL Tennessee |      | PARTS LIST  | TOTAL NO. OF UNITS | ENG. RELEASE BY - DATE  |       |        | PROJ./WORK ORDER NO. |        |
|--|------|----------------|------------|------------------|------|-------------|--------------------|-------------------------|-------|--------|----------------------|--------|
|  |      |                |            | REV.             | DATE |             |                    | PLANNER - DATE          | ACCT. | PLANN. |                      | STORES |
| 0303-9324-1  | E    |                |            |                  |      | 5/27/75 nlp | 1/2                |                         |       |        |                      |        |
| DWG. ASSEMBLY, SFIH-270-3 E.B. SOURCE (SPECIAL - WATER LINES OUT BOTTOM)<br>JOB TITLE SFIH-270-3<br>NEXT ASSY FINAL ASSY |      |                |            |                  |      |             |                    |                         |       |        |                      |        |
| DESCRIPTION  | ITEM | PART/STOCK NO. | UNIT QUAN. | TOTAL REQ.       | ISS. | CODE        | DEC. FT.           | REMARKS - NOTES - MISC. |       |        |                      |        |
| GASKET, UNION - RL #1/2  | 1    | 0020-4821-2    | 2          |                  |      |             |                    |                         |       |        |                      |        |
| NUT, UNION KNURLED - RL #1/2   | 2    | 0020-4921-2    | 2          |                  |      |             |                    |                         |       |        |                      |        |
| NIPPLE, SOLDER - RL #1/2   | 3    | 0020-5621-2    | 2          |                  |      |             |                    |                         |       |        |                      |        |
| MANUAL, INSTRUCTION  | 4    | 0101-8021-0    | 1          |                  |      |             |                    |                         |       |        |                      |        |
| BAR, SHUNT   | 5    | 0216-1951-0    | 4          |                  |      |             |                    |                         |       |        |                      |        |
| LEAD, FILAMENT   | 6    | 0303-3292-0    | X 2        |                  |      |             |                    |                         |       |        |                      |        |
| ASSEMBLY, EMITTER  | 7    | 0204-5864-0    | X 1        |                  |      |             |                    |                         |       |        |                      |        |
| ASSEMBLY, COIL   | 8    | 0303-9433-0    | X 1        |                  |      |             |                    |                         |       |        |                      |        |
| BLOCK, EMITTER SUPPORT   | 9    | 0303-9502-0    | 2          |                  |      |             |                    |                         |       |        |                      |        |
| MAGNET   | 10   | 0303-9512-0    | 1          |                  |      |             |                    |                         |       |        |                      |        |
| PLATE, BASE  | 11   | 0303-9523-0    | 1          |                  |      |             |                    |                         |       |        |                      |        |
| SHIELD, COIL   | 12   | 0303-9532-0    | 1          |                  |      |             |                    |                         |       |        |                      |        |
| PIECE, POLE - L.H.   | 13   | 0303-9564-1    | 1          |                  |      |             |                    |                         |       |        |                      |        |
| PIECE, POLE R.H.   | 14   | 0303-9564-2    | 1          |                  |      |             |                    |                         |       |        |                      |        |
| BRAZEMENT, CRUCIBLE  | 15   | 0303-9594-0    | X 1        |                  |      |             |                    |                         |       |        |                      |        |
| SHIELD, MAGNET   | 16   | 0303-9631-0    | 1          |                  |      |             |                    |                         |       |        |                      |        |

4. Inspect the crucible for evaporant deposit. Clean the crucible as necessary. Thermal shorts are caused by evaporant deposit build-up.
5. The preferred method for cleaning is by air blasting with glass bead honing powder. Alternate methods are wet scrubbing with an abrasive cleaner or chemical cleaning. Insulators are vacuum grade. Chemical cleaning is not generally effective.

Re-assembling the Source:

When re-inserting threaded fasteners, a light coat of molydisulfide is to be applied to the threaded area. This will prevent seizures at high temperatures. Use either a dry type, a spray, or a liquid with water, freon, or other volatile solvent. AVOID the oil-base type, as the oil will create an outgassing problem. Airco Temescal stocks a spray type, Rocol Model DSFM, Part Number 8444-0002-0.

### VIII. TROUBLE-SHOOTING CHART

| <u>SYMPTOM</u>  |            |            | <u>MOST LIKELY TROUBLE</u>   | <u>CORRECTION</u>   |
|---|------------|------------|--|---|
| <u>Emission Filament</u>  |            |            |  |   |
| <u>KV</u>   | <u>AMP</u> | <u>AMP</u> |  |   |
|   | normal     |            |  |   |
| 4-10  | 0.1-2      | 28-75      |  |   |
| OK  | 0          | 0          | 1) Filament loose  | 1) Check that the filament is properly positioned. Check that the filament screws are tight.  |
|   |            |            | 2) Open circuit in filament circuit or power supply.               | 2) Check filament circuit and power supply. Insure that all connections from power supply to filament are tight and test for good continuity. |
| 0   | 1          | OK         | High-resistance ground in system or gun.                           | Check system, starting with feedthroughs  |
| 0   | 0          | OK         | Power supply   | Check power supply.   |
| OK  | OK         | High       | Filament helix shorted.  | Replace filament (cannot repair).   |
| Emission voltage and amperage kicking up and down (plus visible arcing or heat at high-voltage insulators). |            |            | High-voltage insulators fouled or failed.                          | Examine insulators:<br>a) If fouled by conductive deposits, clean.<br>b) If physically damaged, replace (cannot repair).                      |
| OK  | OK         | OK         |  |   |
| 1) Beam spot not centered longitudinal direction.   |            |            | 1) Focus current unadjusted.                                       | 1) Adjust the focus current.  |
| 2) Beam spot will not move when adjusting focus current   |            |            | 2) Electromagnet not working, possible open circuit in focus coil. | 2) Check power to the focus coil. If open circuit in focus coil, replace.   |
| OK  | OK         | OK         |  |   |
| Excessive longitudinal coil current.  |            |            | Main field permanent magnet weak.                                  | Charge or replace permanent magnet  |

| <u>SYMPTOM</u>  |            |            | <u>MOST LIKELY</u><br><u>TROUBLE</u>               | <u>CORRECTION</u>   |
|---|------------|------------|--|---|
| <u>Emission Filament</u>  |            |            |  |   |
| <u>KV</u>   | <u>AMP</u> | <u>AMP</u> |  |   |
|   | normal     |            |  |   |
| 4-10  | 0.102      | 28-75      |  |   |
| OK  | OK         | OK         | 1) Parts not in correct alignment.                 | 1) Check that all parts are tight and snug, and that the filament is correctly inserted and is not warped or sagging. |
| Beam spot not centered in lateral direction or tails on one side of the spot. |            |            | 2) Pole pieces or other parts damaged.             | 2) Repair or replace damaged parts.   |
| OK  | OK         | OK         | 1) Emitter assembly out of adjustment.             | 1) Check that the emitter assembly is secured tight against the mounting blocks.                                      |
| Melt wetting or eroding crucible.   |            |            | 2) Insufficient water flow.                        | 2) Check that the cooling water is flowing through the crucible at a minimum of 4 gal. per minute.                    |
|   |            |            | 3) Beam off center and/or focus too close to edge. | 3) Re-adjust the focus current so that the beam is centered in crucible.  |

IX. PARTS LIST

| <u>Part Number</u> | <u>Description</u>                   | <u>Mat'l</u> |
|--------------------|--------------------------------------|--------------|
| 0020-4821-2        | Union Gasket, 1/2"                   | Viton-A      |
| 0020-4921-2        | Union Knurled Nut, 1/2"              | 304-SST      |
| 0303-3292-0        | Filament Lead                        | Copper       |
| 0020-5621-2        | Solder Nipple, 1/2"                  | 304-SST      |
| 0303-9334-9        | Emitter Assembly                     |              |
| 0303-3122-3        | Filament Buss Bar-Pair               | Tantalum     |
| 0303-3131-0        | Flanged Insulator                    | Alumina      |
| 0303-3152-0        | Emitter Support Bracket              | 304-SST      |
| 0303-3161-0        | Support Stud                         | 304-SST      |
| 0303-6721-0        | Locating Insulator                   | Alumina      |
| 0303-9351-0        | Filament                             | Tungsten     |
| 0303-9362-0        | Cathode Block - L.H.                 | Molybdenum   |
| 0303-9372-0        | Cathode Block - R.H.                 | Molybdenum   |
| 0303-9382-0        | Filament Clamp                       | Molybdenum   |
| 0303-9392-0        | Beam Former                          | Tantalum     |
| 0303-9402-0        | Anode                                | Tantalum     |
| 0303-9412-0        | Mounting Bar                         | 304-SST      |
| 0303-9422-0        | Emitter Support Bar                  | 304-SST      |
| 0418-4631-0        | H.V. Spacing Insulator               | Alumina      |
| 1321-1251-0        | Screw, Soc. Hd. Cap, #6-32x3/16" 1g. | SST          |
| 1321-1252-0        | Screw, Soc. Hd. Cap, #6-32x1/4" 1g.  | SST          |
| 1321-1254-0        | Screw, Soc. Hd. Cap, #6-32x3/8" 1g.  | SST          |
| 1321-1255-0        | Screw, Soc. Hd. Cap, #6-32x1/2" 1g.  | SST          |
| 1360-1200-0        | Nut, Machine Hex, #6-32              | SST          |

